

NF-02-PE Specification

Version V1.0

Copyright ©2019

Disclaimer and copyright notice

The information in this article, including the URL address for reference, is subject to change without prior notice. The Documentation is provided "as is" without any warranty, including any warranties of merchantability, fitness for a particular purpose, or non-infringement, and any warranties mentioned in the proposal, specification or sample. This document is not responsible for any infringement of any patent rights arising out of the use of the information in this document. No license, express or implied, by estoppel or otherwise, is hereby granted.

The test data obtained in this paper are all obtained by Ai-Thinker laboratory, and the actual results may be slightly different. The Wi-Fi alliance membership mark is owned by the WiFi alliance.

All trade mark names, trademarks and registered trademarks mentioned herein are the property of their respective owners and are hereby declared.

The final interpretation right is owned by Shenzhen Ai-Thinker Technology Co., Ltd.

Note

The contents of this manual may be changed due to the version upgrade of the product or other reasons. Shenzhen Ai-Thinker Technology Co., Ltd. reserves the right to modify the contents of this manual without any notice. This manual is only used as a guide, and Shenzhen Ai-Thinker Technology Co., Ltd. makes every effort to provide accurate information in this manual, but Shenzhen Ai-Thinker Technology Co., Ltd. does not ensure that the contents of the manual are completely true. All statements and information in this manual, and the recommendations do not constitute for any warranty, express or implied.

Overview

NF-02-PE is a 100mW power wireless transceiver integrated 2.4G module, embedded nRF24L01+ RF chip; DIP-8 packages that can be quickly docked to existing products ;-altitude medium rate (up to 2 Mbps), using SPI interface, high stability, high performance-price ratio. NF-02-PE suitable for a variety of Internet of things occasions, widely used in wireless mouse, wireless remote control, somatosensory devices, active RFID,NFC, low-power ad hoc wireless sensor nodes are Internet of things applications Ideal product.

Appearance dimensions

Chip image

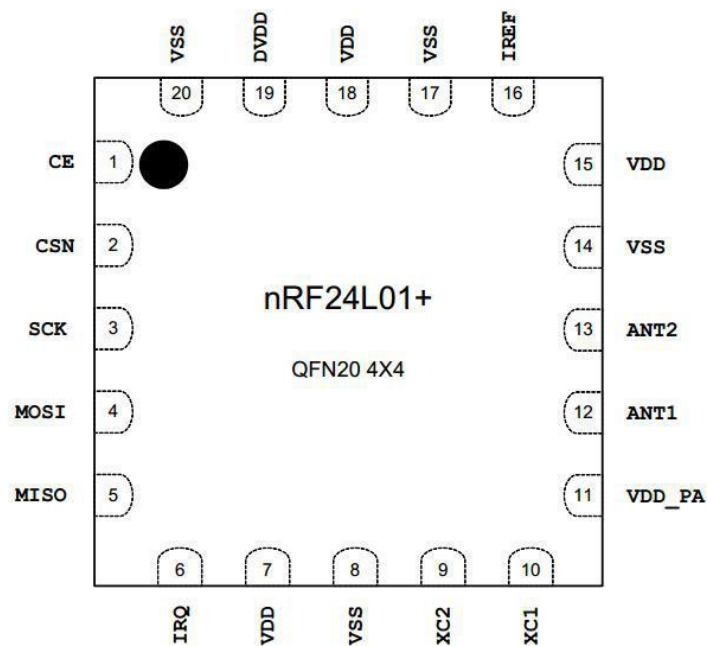

NF-01-N Module image

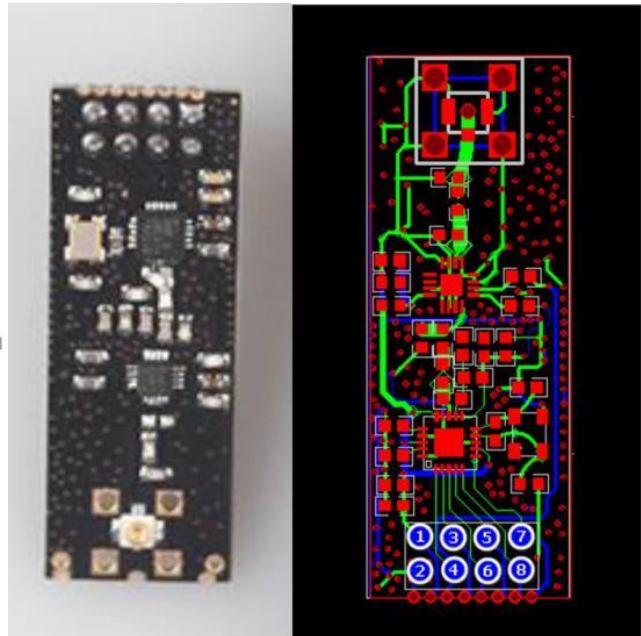
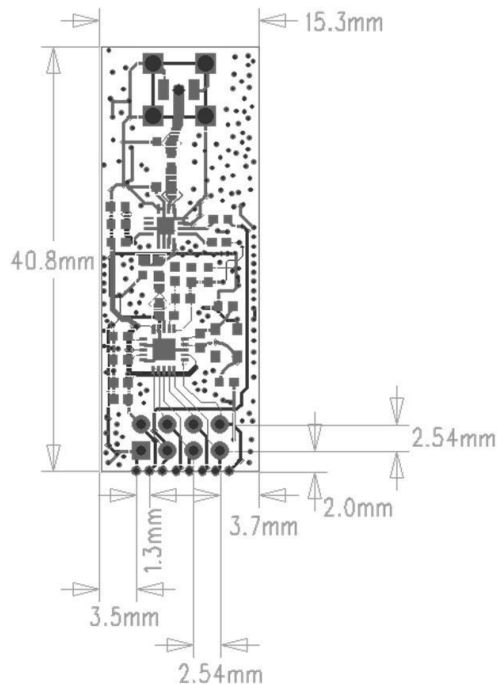

No.	Parameter Name	Parameters	Note
01	RF chip	nRF24L01+	Nordic
	Power amplifier chip	RFX2401C	Power amplification, increase gain
02	module size	40.8*15.3 unit:mm	±0.2mm
03	Modulation mode	GFSK modulation mode	Gaussian frequency shift keying
04	Package	DIP-8	
05	Interface	Adopt four-wire SPI interface	SPI port Maximum rate not greater than 10 M
06	Transmission power	Maximum is 20 dBm	Others refer to chip datasheet
07	RSSI support	Support	Signal received strength detection
08	Operating frequency	2.4GHz ~ 2.525GHz	Adjustable, 1MHz
09	Voltage range	1.9 ~ 3.6V, typical value 3.3	Excessive voltage would damage the module
10	Data rate	support 2Mbps/1Mbps/250Kbps	More details refer to chip datasheet
11	Channel	126 RF Channel	Each channel is separated 1MHz
12	Test range	100m	Sunny, no barrier, maximum transmit power
13	Receiving sensitivity	-94dBm@250Kbps	other details refer to chip datasheet
14	Antenna interface	On-board pcb antenna	
15	Emission length	Single packet 1~32 byte	3class FIFO
16	Received length	Single packet 1~32 byte	3class FIFO

17	Operating temperature	-20 ~ + 70°C	excessive temperature would damage the module
18	Storage temperature	-40 ~ +125°C	excessive temperature would damage the module
19	Standby current	26μA	other details are chip manual
20	Receive current	13.5 mA (2Mbps)	for other details see Chip Manual
21	Emission current	11.5mA (0dBm)	for other details see the chip manual

Pin definition

Name	Direction	Purpose
VCC	-	power supply must be between 1.9~3.6 V
GND	-	ground wire, connected to power reference ground
CSN	input	module chip select pin for starting a SPI communication
CE	input	module enables control foot, CE low level is in standby mode
MOSI	input	module SPI data input pin
SCK	input	module SPI bus clock
IRQ	output	module interrupt signal output, low level effective
MISO	output	module SPI data output pin

Pin definition image

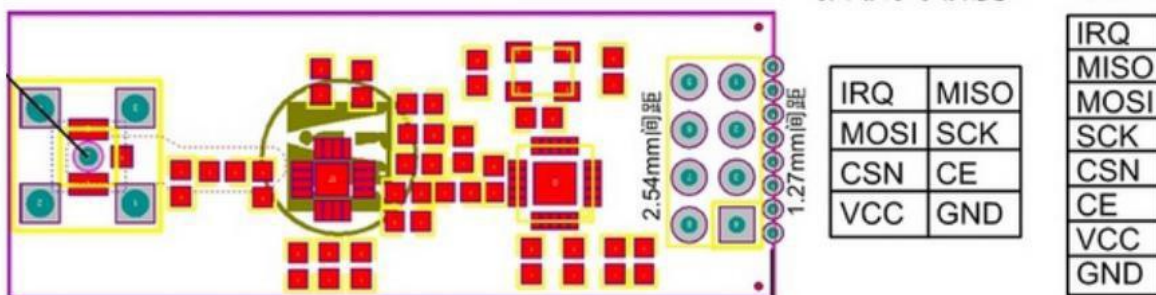

Noted

01. Electrostatic----- high frequency analog devices are electrostatic sensitive, please avoid contact with electronic components on the module as far as possible
02. Power-----supply to ensure that the power supply must have a small ripple, to avoid a large run out of the power supply voltage value, it is recommended to use π type. Filter (Ceramic Capacitor/Tam Capacitor Inductor)
03. Ground wire-----module ground wire using single point grounding mode, recommended to use 0 oh resistance, or 0 mH inductance, other parts of the electricity refer separated

04. Antenna-----If the antenna is covered by a metal shell, some components will affect the performance of the antenna, such as relays. Make sure the antenna is exposed, preferably vertically up

05. Interference-----If there are other wireless modules in the same product, it is necessary to plan the frequency reasonably and adopt shielding measures,

06. Crystal oscillator----- Reduce the effect of harmonic interference and intermodulation interference. If there is a crystal oscillator near the circuit board of the module, please increase the straight line distance between the crystal oscillator and the module.

Typical circuit

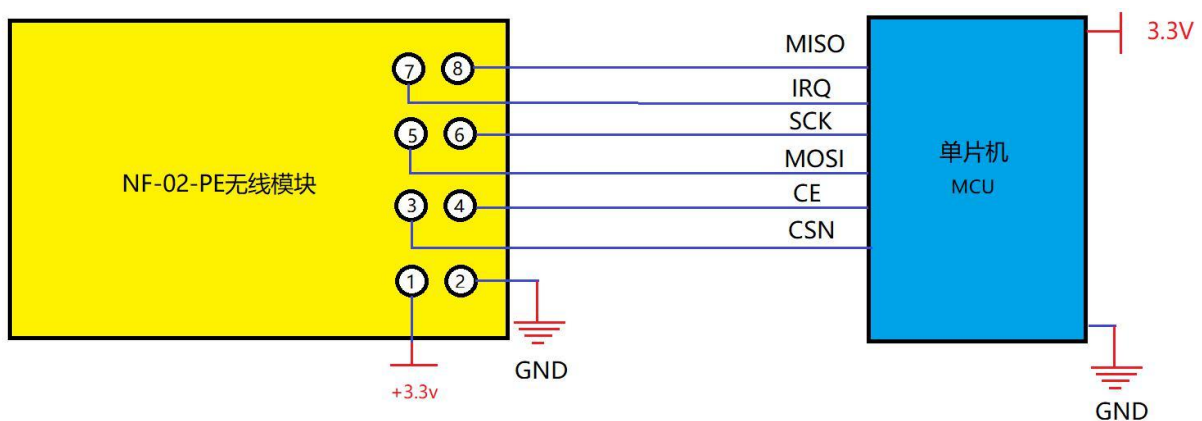

schematic diagram of the connection between MCU and NF-02-PE

Contact us

Official website: <https://www.ai-thinker.com>

Development DOCS : <http s : //docs.ai-thinker.com>

Official Forum: <http://bbs.ai-thinker.com>

Sample purchase: <https://anxinke.taobao.com>

Business cooperation: sales@aithinker.com

Technical support: support@aithinker.com



Company Address: Building C, Huafeng Intelligent Innovation Port, Xixiang, Baoan District, Shenzhen

Tel : 0755-29162996